

Lista de piezas de recambio / List of spare parts

Número Number	Descripción Description	Ref. repuesto Spare part ref.
1	Pantógrafos Pantographs	HN2536 HN2537 HN2535/01 HN2537/01
2	Línea de alta tensión High voltage line cables	HN2536/02
3	Aros de adherencia Traction tyres	HN2535/03
4	Accesorios frontales Front accessories	HN2536/04
5	Difusores de luz Lightpipes	HN2536/05
6	Conjunto PCBs y luz PCB and light assembly	HN2536/06
7	Toperas Buffer beams	HN2536/07
8	Conjunto ejes Wheel sets	HN2536 HN2537 HN2535/08 HN2537/08
9	Motor con volantes Motor and flywheels	HN2535/09
10	Mecanismos de enganche Coupler mechanisms	HN2535/10
11	Bogies completos Complete bogies	HN2535/11
12	Accesorios del techo Roof accessories	HN2536/12

Esta locomotora está equipada con un conector digital NEM 662 (también conocido como Next18). Cualquier decoder de este tipo de diversos fabricantes (ESU, Lenz, Viessmann, ZIMO,...) que utilicen este formato pueden ser usados para controlar esta locomotora. Antes de su uso, es probable que tenga que programar su decoder de forma adecuada (mapeado de funciones).

This locomotive is fitted with a NEM 662 digital connector (also known as Next18). Any decoder from any supplier (ESU, Lenz, Viessmann, ZIMO,...) using this standard can be used to control this locomotive. Before to use it in this locomotive, most likely you have to program your decoder accordingly (function mapping).

Configuración de luces - Modo digital

Revise el manual del decoder DCC para el mapeo de salidas de funciones F1, F2, etc. (mapeado de funciones).

Light configuration - Digital mode

Check on the manual of the installed DCC decoder the mapping of the outputs with the functions F1, F2, etc. (functions mapping).

Número Output	Función Function
F0	Luces frontales Head lights
AUX1	Luz roja cabina 1 Cabin 1 red light
AUX2	Luz roja cabina 2 Cabin 2 red light
AUX3	Foco cabina 1 Cabin 1 upper light
AUX4	Foco cabina 2 Cabin 2 upper light



www.arnold-modeleisenbahnen.de

Cómo desmontar la locomotora:

How to disassemble the locomotive:

1. Retire la manguera decorativa de ambos extremos.
Remove the decorative hose from both ends.

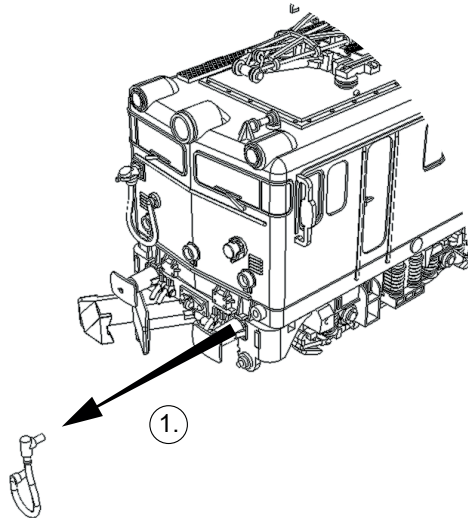

2. Abra la carrocería separando las pestañas del chasis en ambos laterales.
Open the bodyshell by releasing the clips on both sides.

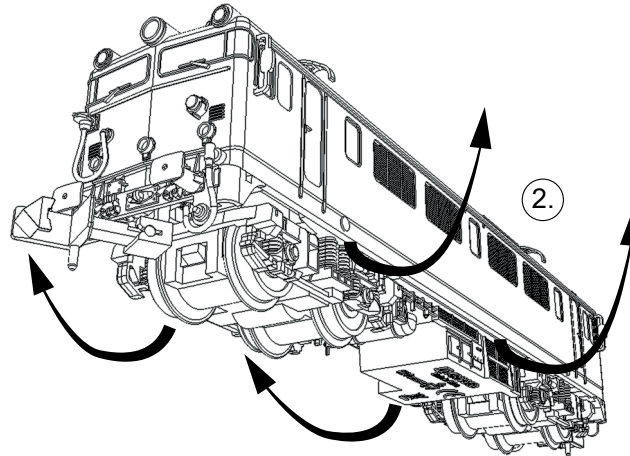

3. Separe la carrocería del chasis tirando hacia arriba.
Separate the bodyshell from the chassis.

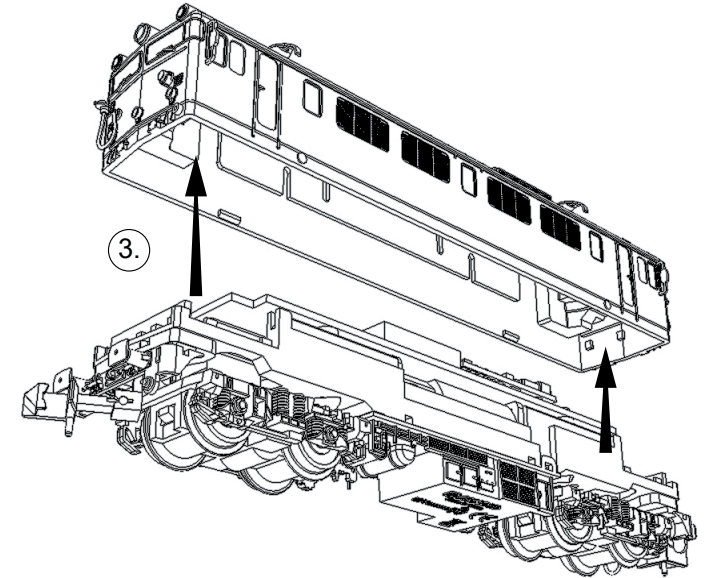

Cómo instalar un decoder digital:

How to install a digital decoder:

1. Retire con cuidado el enchufe falso del conector digital Next-18 (NEM 662).
Carefully remove the dummy plug from the Next-18 (NEM 662) digital plug, please.
2. Inserte el decoder Next-18 (NEM 662) asegurando la correcta posición.
Insert the Next-18 (NEM 662) digital decoder making sure the correct position.

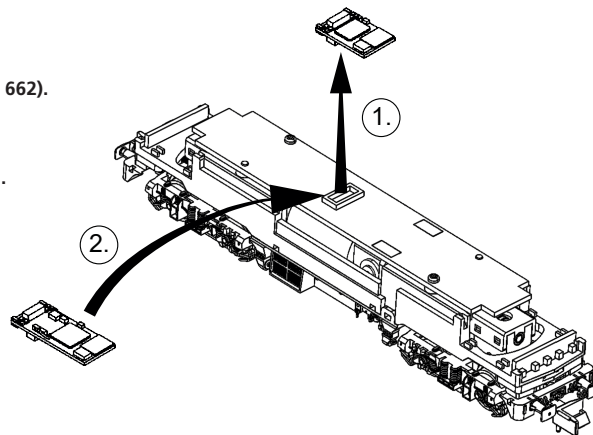

Dónde engrasar:

Where to grease:

